

CELLWOOD MACHINERY AB

INFORMATION

GRUBBENS REJECT SEPARATOR

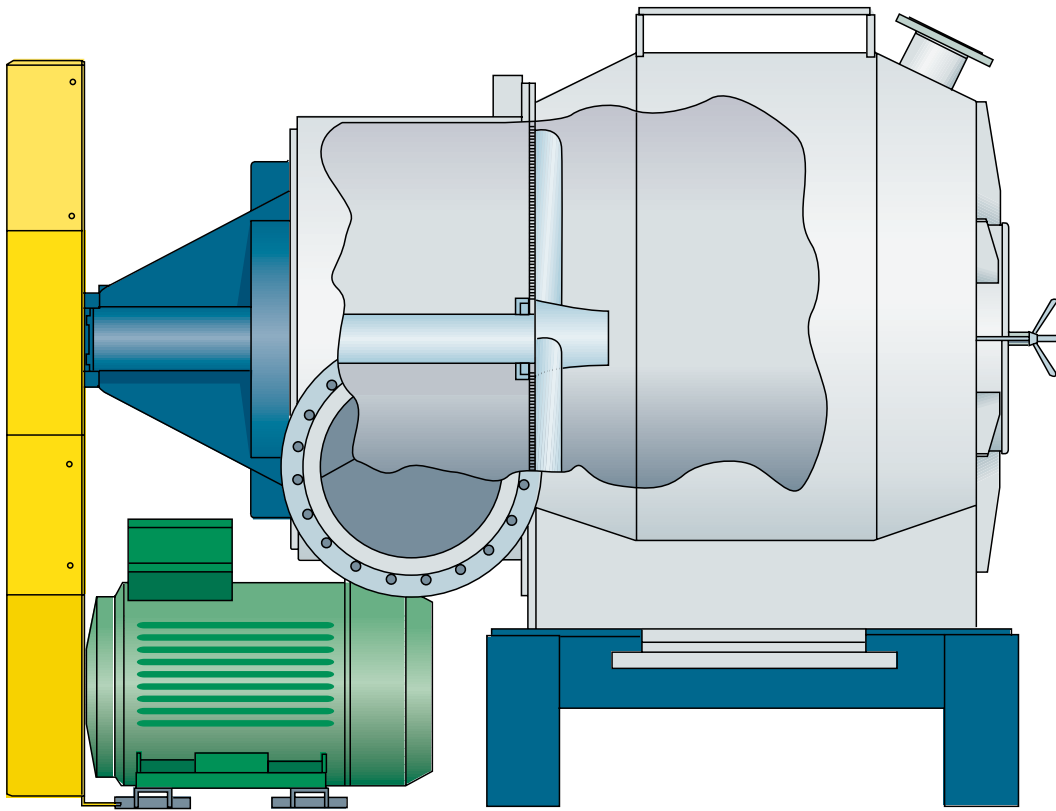

**A pulper cleaning equipment
for LC, MC and HC pulper**



Cellwood Machinery
FOR BETTER PULP AND PAPER

CELLWOOD MACHINERY AB

INFORMATION



Reject separator in connection with a HC pulper.

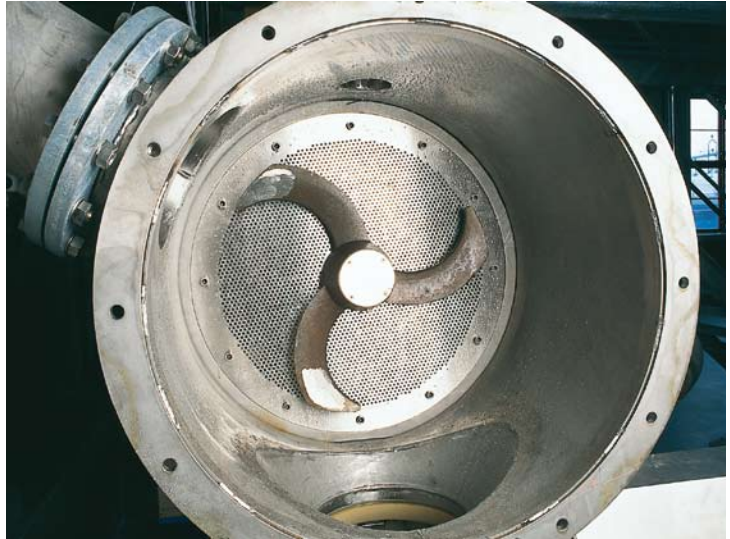

TECHNICAL DATA

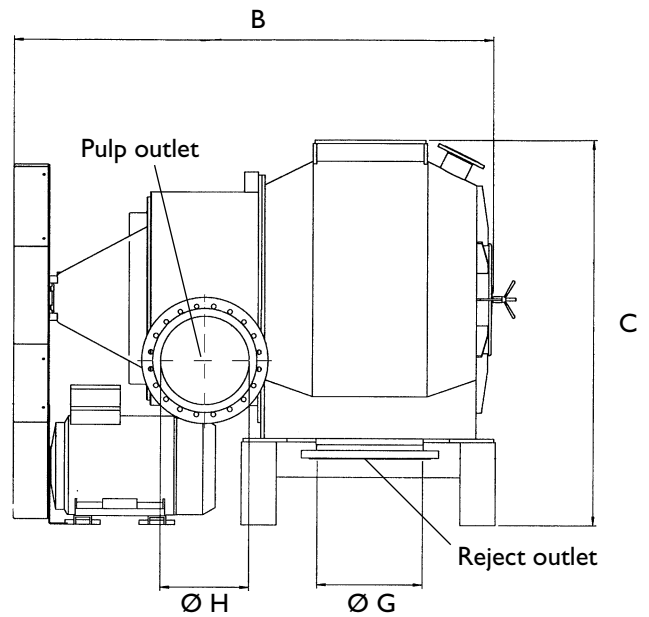
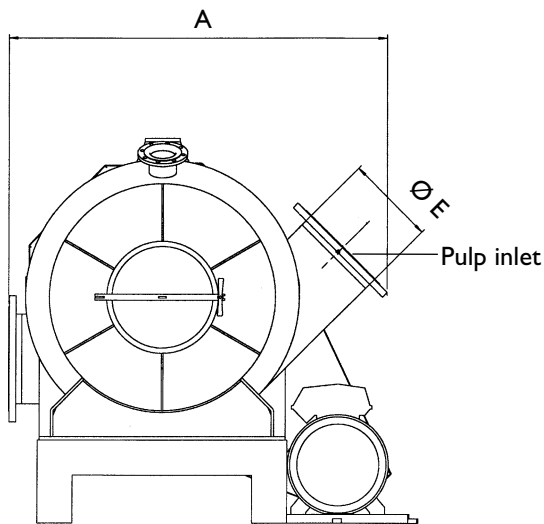

Type	A	B	C	Ø E	Ø G	Ø H	Flowrate (l/min) at 5%	Inst. Power
GRS 250	1050	1700	1180	250	300	250	3200	11-15 kW
GRS 1000	1690	2310	1990	400	500	400	8000	45-55 kW
GRS 2000	2150	2720	2110	500	600	500	13000	75-90 kW
GRS 3000	2360	3030	2360	600	600	600	19500	90-110 kW
GRS 5000	3030	3260	2860	700	700	700	28500	110-132 kW



Cellwood Machinery
FOR BETTER PULP AND PAPER

CELLWOOD MACHINERY AB • BOX 65 • SE-571 21 NÄSSJÖ • SWEDEN • PHONE +46 380-760 00 • FAX +46 380-141 23 • E-mail sales@cellwood.se • www.cellwood.se
STREET ADDRESS • STORGATAN 53 • SE-571 32 NÄSSJÖ • SWEDEN

— a member of the Cellwood Group —